



Arkeia Network Backup is a fast, easy-to-use network backup solution designed for data protection in mid-sized organizations. Protect both physical and virtual environments with solutions from Arkeia.

## Arkeia Network Backup Suite: Version 9

Ensuring the availability of data is among the most important and difficult tasks for information technology (IT) professionals. This task grows more complex with the advent of new regulations, changing IT environments, and reduced IT budgets. But backing up data doesn't have to be complicated, time consuming, or expensive.

The award-winning Arkeia Network Backup Suite Version 9 delivers features to increase reliability and flexibility, to reduce costs, and to improve backup performance for both physical and virtualized environments.

### Enterprise Features for Mid-Size Organizations

Arkeia offers the enterprise-class capabilities—features, platform support, and web-based interface—required by mid-sized organizations without the complexity that would require a team of software administrators to deploy.

### Protection for Physical and Virtual Systems

Arkeia Network Backup supports all four of the leading virtualization solutions: VMware's vSphere®, Microsoft's Hyper-V, Citrix's XenServer, and Red Hat's RHEV. Arkeia also supports over 200 combinations of processor architecture and operating systems. Learn more on page 2.

### Top-tier Technical Support

Arkeia's technical support and service teams are second to none. As backup software specialists, our service engineers are experts in systems and storage, and in data protection best practices. The same California- and France-based engineers that deliver consulting and training also staff our support operation. Learn more on page 6.

### Proven Solutions for Data Protection

Arkeia Software, with headquarters in California, has delivered data protection solutions to customers around the world since 1996. Arkeia invests heavily in software innovation and delivered the industry's first professional backup solution for Linux, first virtual appliance for backup, and first implementation of progressive deduplication technology for backup. Learn more on page 6.

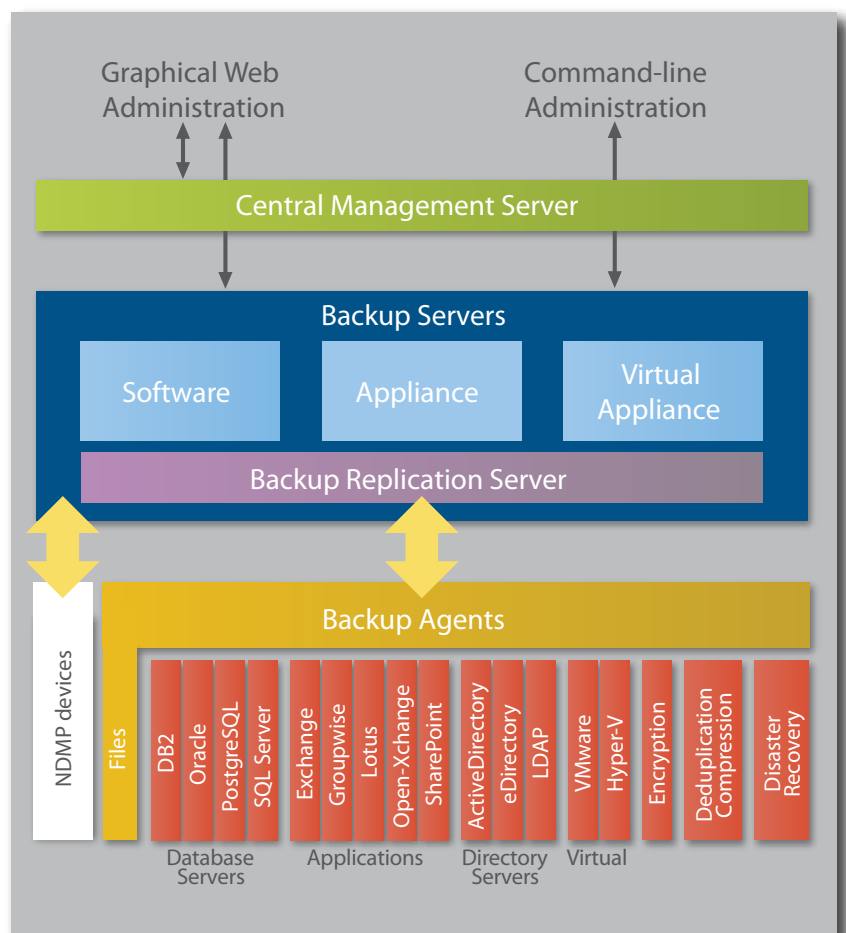

## Supported Platform Categories

- Apple MacOS X
- FreeBSD
- HP-UX
- HP-Compaq-Digital Tru64
- IBM AIX
- Linux (Generic) glibc
- Linux Debian
- Linux Mandriva Enterprise Server
- Linux Mandriva Corp. Server
- Linux Novell SLES
- Linux Novell Suse
- Linux Fedora
- Linux Redhat Enterprise Linux
- Linux Slackware
- Linux Ubuntu
- Linux Novell OES
- Linux Yellowdog
- NetBSD
- Novell Netware
- OpenBSD
- SCO UnixWare, OpenServer
- SGI IRIX
- SUN Solaris
- VMware vSphere, ESX/ESXi
- Windows 98/XP/Vista/7
- Windows Server NT4,2000/2003/2008



## Single, Integrated Product

Arkeia Software is singularly dedicated to delivering the industry's best backup software for mid-sized organizations. The Arkeia Network Backup Suite was engineered as a complete network backup solution based on a kernel for high-speed data transfer. Capabilities of our backup servers and backup agents are enabled or disabled with license keys to simplify deployment and maintenance.

While Arkeia has purchased companies to gain exceptional technology (e.g. Kadena Systems for progressive deduplication technology), we have never tried to integrate an existing product to our own. Arkeia Network Backup capabilities are delivered with a single, consistent architecture that allows data protection to be fast, easy-to-use, and reliable.

## 200 Platforms: One Backup Solution

Arkeia offers Backup Agents for over 200 platforms, supporting virtually all Linux and Windows platforms, as well as AIX, BSD, HP-UX, Irix, Macintosh, Netware, and Solaris. See the complete list at <http://www.arkeia.com/platforms>.

We also offer specialized agents for hot backups of open files used by important applications, databases, directory servers, and virtualization hypervisors. See the complete list at <http://www.arkeia.com/agents>.

## Secure Storage on Disk, Tape, and Cloud

Arkeia Backup Servers support direct backup to disk and tape with replication to disk, tape, and public or private clouds. Arkeia supports all storage devices that respect the SCSI II standard—over 600 devices and virtually all tape drives, autoloaders, and libraries.

Arkeia encrypts data (AES-256) at the source, guaranteeing secure transmission over the LAN, even to remote storage. We even write on every backup tape the C-language source code to restore your data. So, even if you've lost our software, you'll always be able to restore your data.

## Easy to Deploy; Easy to Administer

Download Arkeia Network Backup software (or firmware) from our web site. All software products bundle a free 30-day license to let you evaluate the software.

Configure and administer the products using either our Web-based graphical user interface or our command-line interface (CLI). The CLI allows administrators to script repeated tasks. Because both interfaces are built on the same foundation, the same operations can be performed identically through either interface.

Support for pre- and post-backup scripts allows administrators to execute custom commands before and/or after a backup job.



## ▶▶ Arkeia Network Backup Suite Components

Arkeia Network Backup Suite consists of its core Backup Servers and Backup Agents, and the advanced Backup Replication Server and Central Management Server. The Arkeia Suite employs several advanced technologies to achieve optimal performance. For example, Arkeia parallelizes data streams for backups—even backups direct-to-tape. Arkeia accelerates restores by writing (but never overwriting) the precise files required to meet the target recovery point.

### Backup Servers

An Arkeia Backup Server controls Backup Agents and manages the backup process and storage devices, whether disk, tape, or cloud resources. The web server for Arkeia's user interface is usually installed on the Backup Server, but can be installed elsewhere. Arkeia Servers can be deployed as appliances, virtual appliances, or software application for over 100 AIX, HP-UX, Linux, and Solaris platforms. Read more about our appliances on the back of this datasheet.

Backup Servers are composed of Catalog Servers and Media Servers. The Arkeia Remote Storage Option allows a Media Server to be installed on a client machine in order to manage storage devices connected to that machine.

The Arkeia Shared Storage Option allows multiple Media Servers to share a single storage device across a storage area network (SAN). Arkeia supports LAN-free backups using both SANs and virtual LANs.

Arkeia Backup Servers support the Network Data Management Protocol (NDMP) to provide agentless backups of network attached storage devices and to save backups to these devices. Other capabilities include backup replication (D2D2D), Disk-to-Disk-to-Tape, Tape Duplication, and replication/archiving to the cloud.

### Backup Agents

Arkeia Backup Agents, installed on the data source computers, perform the backup of individual data sources. Arkeia Generic Backup Agents protect over 200 computer platforms with software installation packages specific to each platform (architecture and operating system pair). These Generic Agents backup files and system data structures required by each operating system. For example, all Arkeia Backup Agents for Microsoft Windows platforms back up the Registry, Certificate Service, Event Logs, and Com+ data structures.

Application Agents
Microsoft Exchange
Novell GroupWise
Lotus
Open-Xchange
Microsoft SharePoint

Database Server Agents
IBM DB2
Microsoft SQL Server
MySQL
Oracle
PostgreSQL

Directory Server Agents
Microsoft Active Directory
Novell eDirectory
LDAP

Virtual Machine Agents
VMware vSphere
Microsoft Hyper-V

In addition to Generic Backup Agents, Arkeia offers Specialized Backup Agents for hot backups of important applications, database servers, directory servers, and virtualization hypervisors. These Agents leverage application programming interfaces (e.g. Microsoft VSS, VMware vStorage, Novell SMS) furnished by each software vendor. Specialized Backup Agents are listed, below-left. Get more information at <http://www.arkeia.com/agents>.

Backup Agent Options include client-side ("source-side") Deduplication, Compression, and Encryption. Putting deduplication, encryption, and compression on the client-side distributes CPU load across many client machines rather than centralizing it on the backup server. This architecture shortens backup periods and improves server scalability.

All Backup Agent and Options features are managed through the command-line and graphical user interfaces of the Backup Server.

### Bare-metal Disaster Recovery

Arkeia offers bare-metal restores for Linux and Windows Server platforms. We support the full range of Windows Servers, including Windows NT, 2000, XP, Vista, 2003, 2008, and 7. Linux disaster recovery is supported on all x86 platforms, both 32-and 64-bit, for all Linux distributions.

With bare-metal Disaster Recovery the restore process includes restoring data structures necessary to make the target machine bootable. Disaster Recovery leverages full, differential, and incremental backups, as well as backups of both file- and non-file data. Arkeia also allows off-line backups that record a block-by-block image of any disk.

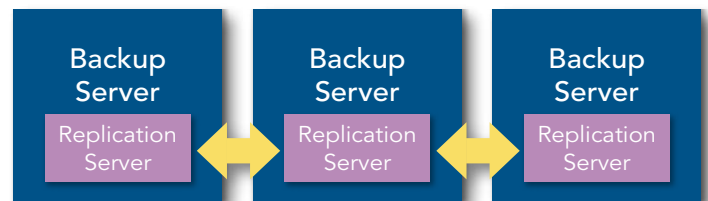

### Backup Replication Servers

The Arkeia Backup Replication Server copies backup sets among Backup Servers across a wide area network (WAN). Replication of encrypted, deduplicated, and compressed backup data is the foundation of Arkeia's backup-to-cloud offering.

Backup Replication ensures that backup sets are both protected and readily accessible. Backup Replication offers interactive, chained, and scheduled copying of data coming from total, differential, and incremental backups. First, backups are performed to disk, keeping backup windows to a minimum. After the backup is complete, a Backup Replication Server transfers the backup set from the Media Server storage to a Catalog Server on a remote computer.

### Central Management Servers

Administrators use the Arkeia Central Management Server to manage multiple Backup Servers from a single dashboard.

The central dashboard allows improved control of the backup process due to reporting on backup performance (e.g. backup window, disk and tape utilization, partial or failed backups). Further, global data management policies can be implemented to ensure corporate policies and regulatory requirements are met.

## Virtualization

Arkeia has delivered broad protection of virtualized environments since 2008. Today, Arkeia protects VMware vSphere, Microsoft Hyper-V, Citrix XenServer, Red Hat RHEV, and Parallels.

A single Arkeia agent can efficiently create a backup image of all the virtual machines on one hypervisor. When the API allows incremental image backups or file-level restores from image backups, Arkeia uses these capabilities. When virtualization vendors make available APIs to quiesce and snapshot one or more virtual machines, Arkeia builds dedicated agents. Arkeia's first two dedicated agents were based on VMware's vStorage, and Microsoft's VSS.

### VMware vSphere via vStorage

Arkeia's Backup Agent for vStorage delivers all the capabilities of vSphere 4.X, including Changed Block Tracking (CBT) which can accelerate incremental backups by more than 10x. File-level restore complements vStorage image backups by retrieving individual files quickly. Arkeia also supports thin-full-backups, where only used blocks are backed up and stored.

The Arkeia backup agent offers auto-discovery, auto-inclusion, and auto-protection of virtual machines in the backup schedule. It supports vCenter and vApp, protecting virtual machines as they migrate among hypervisors.

### Microsoft Hyper-V via VSS

Arkeia's Backup Agent for VSS provides snapshot-based backups of Microsoft's Hyper-V virtual machines. Arkeia's enhanced support for Volume Shadow Copy Service (VSS) allows administrators to backup both files and transactionally-consistent application data in a single pass. Image-level backup enables disaster recovery for both Linux and Windows guest operating systems, resulting in reduced downtime.

### Arkeia Virtual Appliances

Arkeia provides two virtual appliances for VMware environments. Both the Arkeia Backup Server and the vStorage Backup Agent are packaged as virtual appliances.



Packaging backup servers and agents as virtual appliances speeds deployment and leverages the resource-sharing benefits of virtualized environments. Backup servers are ideal for virtualization because the software only runs periodically and can co-exist on shared hardware.

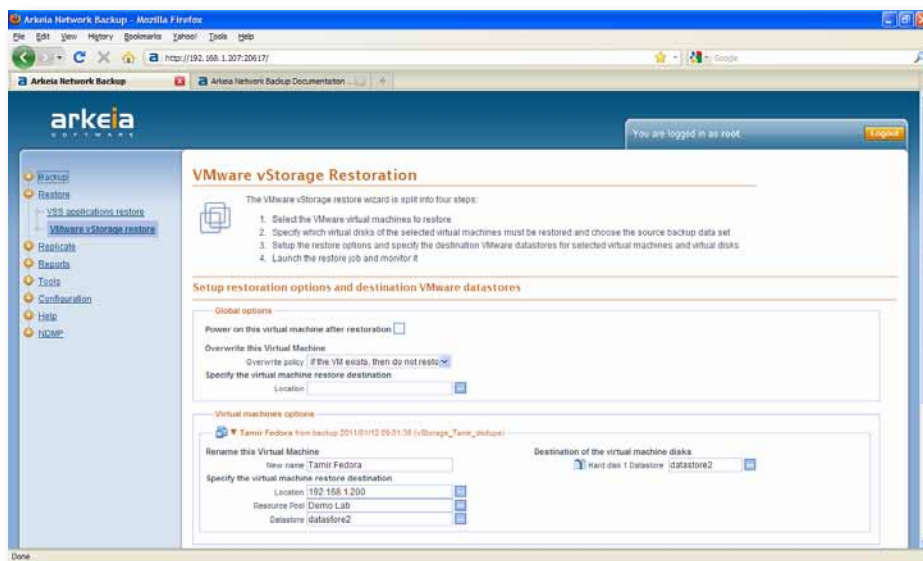

#### Backup Types:

- Full Backups
- Thin-Full Backups
- Block-level Differential Backups
- Block-level Incremental Backups

#### Granularity:

- Image-level
- Image Block-level
- File-level restores

#### vStorage Transport Methods

- LAN and virtual LAN
- SAN
- SCSI Hot-Add

#### vSphere 4.x Platforms

(Protected by Arkeia):

- ESX 4.0, ESX 4.1
- ESXi 4.0, ESXi 4.1
- vCenter 4.0, vCenter 4.1

#### VMware Infrastructure 3 Platforms

(Protected by Arkeia):

- ESX 3.0, ESX 3.5
- ESXi 3.x
- Virtual Center 2.0, Virtual Center 2.5

#### vStorage Operating Systems

(For Installation of Backup Agent):

- Red Hat Enterprise Linux 5
- Red Hat Fedora Core 8
- SUSE Enterprise Server 11
- Ubuntu Desktop 7.10
- Windows Server 2003 SP2,
- Windows Server 2008 SP1 and R2
- Windows Desktop: 7, Vista, XP SP3

## ▶▶ Deduplication and Compression

Arkeia delivers several advanced technologies for data deduplication and compression. These technologies are important primarily because they accelerate backups by reducing the time necessary to transmit data across a network, whether to a tape drive across a LAN or cloud storage across a WAN.

### Progressive Deduplication is Fast

Progressive deduplication improves on traditional “variable-block deduplication” in two ways. First, progressive deduplication is faster, reducing the length of backup windows. Arkeia’s progressive deduplication eliminates the need to scan for block boundaries. All files previously encountered by Arkeia are deduplicated at fixed-block speeds. New data is surveyed with a sliding window. A speedy, light-weight algorithm determines if data under the window is a probable match to blocks in the known-block-pool. Probable matches are scrutinized with a heavy-weight hash algorithm. Because over 99% of probable matches prove to be exact matches, progressive matching is extremely efficient. Arkeia’s patented “progressive matching” technology inspired the name “progressive deduplication.”

### Progressive Deduplication Increases Compression Ratios

Second, progressive deduplication delivers higher compression ratios which save money by reducing storage volume and network performance requirements. Moving less data over the network also accelerates backups.

Variable-block deduplication fixes block boundaries randomly, affording little control over the size of blocks. Progressive deduplication evaluates all possible block boundaries, guaranteeing the best possible deduplication. Precise control over block boundaries allows blocks to be optimally sized for each file type.

### Application-aware

Arkeia deduplication is application-aware. Each type of data, such as executable files, text files, and database records, will be deduplicated with the block size that achieves the maximum compression rate. Arkeia has analyzed hundreds of file types, produced by hundreds of popular applications in the enterprise, to determine each one’s optimal block size. For example, the

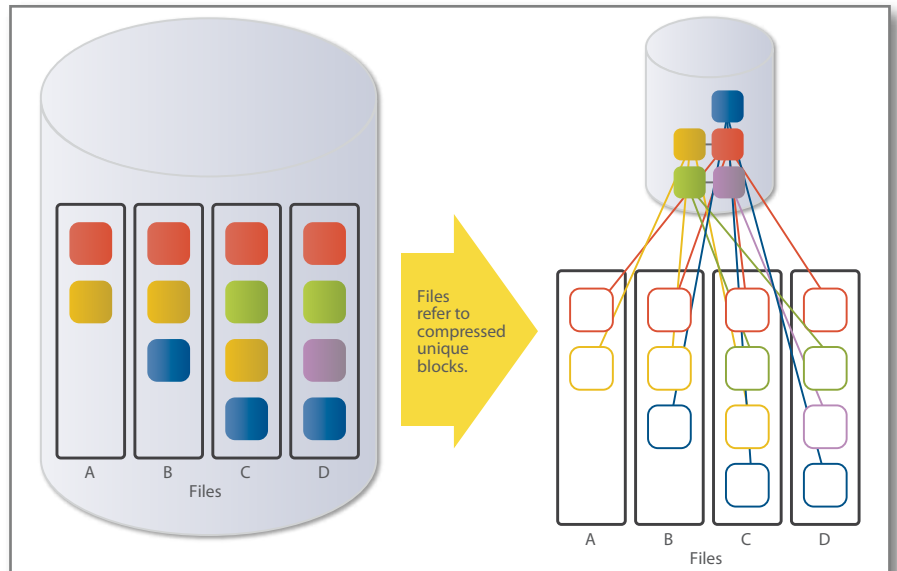

optimum block size for deduplication of Microsoft Powerpoint files is 1,024 bytes, while VMware VMDK files enjoy maximum compression at closer to 4,096 bytes. Because Arkeia controls dedupe block size precisely, we gain an important advantage. Learn more at [www.arkeia.com/dedupe](http://www.arkeia.com/dedupe).

### Advanced Local Compression

After files are decomposed into blocks, Arkeia compresses each block using algorithms optimized for each block size. Most per-file “Zip” compression solutions use DEFLATE (Lempel-Ziv ‘77

Arkeia delivers improved results because Arkeia’s local compression is optimized for each dedupe block size, which are generally less than 64kB.

### Source or Target Dedupe

The greatest benefit of dedupe for backup is faster backups. Dedupe accelerates backups by reducing the volume of data passed over the network. This acceleration requires that deduplication take place at the source, before data are moved over a LAN.

In the unusual case that a server has a slow CPU but a fast network connection, deduplication on the backup server (or media server) may deliver a faster backup. Arkeia supports source-side, target-side and mixed-side deduplication.

### Virtual Machine Deduplication

Deduplication offers obvious benefits when applied to virtual machine backups. Multiple virtual machine disk images typically contain large fractions of duplicate data and most deduplication strategies will uncover some of this duplication.

Arkeia deduplication is ideal for virtual machine backups because its sliding window algorithm accommodates large files that repeat content internally, or that share similar—but not identical—content with other files.

Arkeia typically achieves 40% better compression than variable-block deduplication on virtual machine disk images. See [www.arkeia.com/dedupe](http://www.arkeia.com/dedupe) for more information.

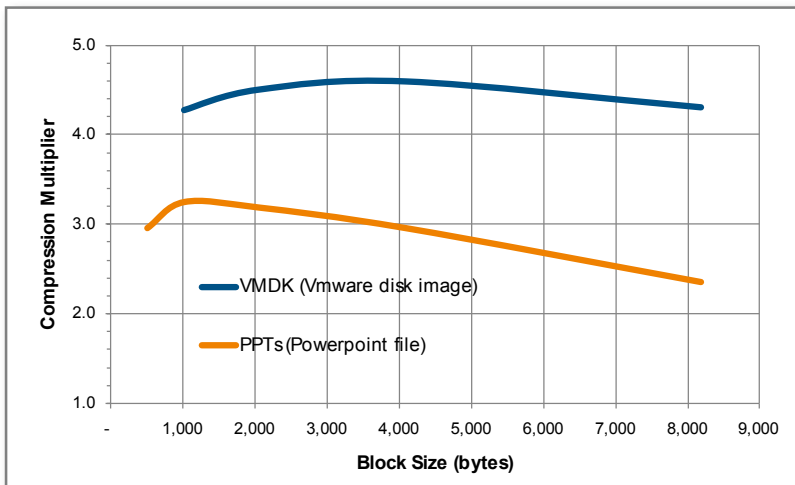

## ▶▶ Three Ways to Deploy Backup Servers

Arkeia Backup Servers can be deployed in three ways: as an appliance, as a virtual appliance, or as a traditional software application. Choose the deployment mode that best fits your requirements.

The same backup server functionality is available, whatever the deployment mode. All deployments offer the same Web-based graphical user interface and command-line interface. Exactly the same Arkeia Backup Agents, Backup Replication Servers, and Disaster recovery software work with all three backup server deployment modes. You can manage multiple Backup Servers—in mixed deployments—with a single Central Management Server.

## Software Applications

Both large data centers and small IT shops gain maximum flexibility when Arkeia Backup Servers are deployed as a software application. Arkeia Backup Servers run on over 110 Linux and UNIX platforms as a software application.

With Arkeia Software Application deployments you choose the hardware, the storage, and the networking technologies: the configuration ideal for your requirements and the exact technology that meets your needs.

## Appliances

Environments without full-time technical resources choose Arkeia's physical appliances for ease of installation, configuration, and operation. Arkeia Physical Appliances match Arkeia software with a tuned operating system, processor, memory, and storage for optimum performance.



Arkeia offers a broad range of appliances, with internal disk storage capacities starting at 1TB and optional LTO tape drives. Internal disk systems include RAID with hot-swappable drives. All power supplies are bi-voltage and some are redundant and hot-swappable. Models are either table-top or rack-mountable.

Storage connectivity ranges from eSATA, to SCSI, SAS, and Fibre Channel. With SSL, and because all unmonitored ports are closed, our appliances are secure. Recommended updates are infrequent. Installation and configuration are simple: (1) plug in the box; (2) set its IP address; (3) use your Web browser to begin backups.

## Virtual Appliances

Administrators with virtualized environments can deploy an Arkeia Backup Server as a virtual machine image. The Arkeia Virtual Appliance supports VMware vSphere environments and integrates (1) Arkeia Network Backup, (2) an optimized Linux operating system, and (3) a VMware hardware description. With virtual appliances, administrators enjoy the convenience of rapid provisioning and the flexibility of foregoing dedicated hardware.

## ▶▶ Support, Consulting & Training

All Arkeia software and appliances include business-hour technical support delivered by Arkeia engineers from offices in California and Europe. 24x7 technical support is optionally available when immediate support is needed for critical restores. Arkeia provides support by email and telephone.

In Latin America and Asia, first-tier technical support is provided in local languages by Arkeia-trained support engineers at Arkeia distributors.

Training and consulting services are available on-site and over-the-wire. Group classes, as well as classes focused on the requirements of a single company, are available. For more information about our support programs and training classes, visit <http://www.arkeia.com/services>.



## ▶▶ About Arkeia Software

Arkeia Software delivers proven solutions for data backup and disaster recovery. The Arkeia Network Backup Suite was designed for mid-sized organizations and protects worldwide more than 100,000 networks for 7,000 enterprise customers in 70 countries.

As backup software specialists, we focus on delivering rock-solid backup solutions. We have assembled a core engineering team with deep expertise in system software in general, and backup software in particular. Our methodical product delivery process has allowed us to deliver products that interoperate seamlessly and consistently. For example, our Version 8 backup servers still support Version 4 backup agents, minimizing costs of software administration.

Arkeia shipped the industry's first network backup solutions for Linux in 1996 and acquired Kadena Systems for its patented deduplication technology in 2009. We are headquartered in San Diego, California.

For more information about Arkeia, visit [www.arkeia.com](http://www.arkeia.com) or email [info@arkeia.com](mailto:info@arkeia.com).